

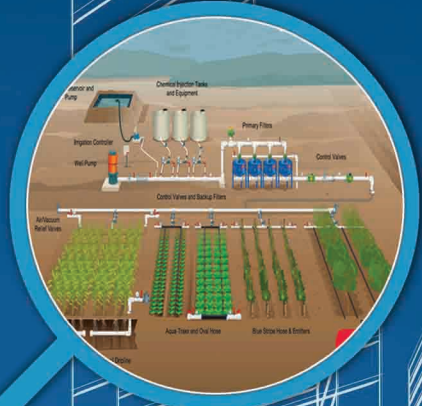

# S4 Co., Ltd

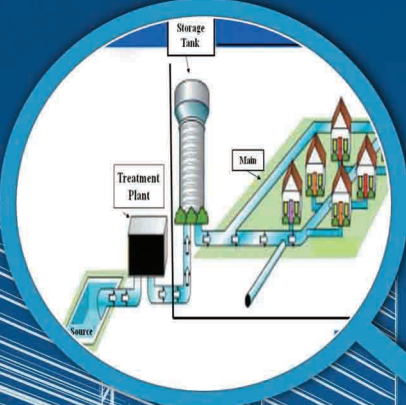



# S4 Co., Ltd

## តារាងតម្លៃបំពង់ជ័រ ប៉េ វេ វេស

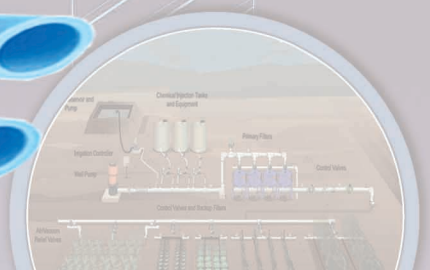

No	DN		Class 5		Class 8.5		Class 13.5	
	Thai Unit	Khmer Unit	Thickness	Showing Price	Thickness	Showing Price	Thickness	Showing Price
1	18(1/2")	21mm			2.00	\$ 1.89	2.50	\$ 2.42
2	20(2/3")	27mm			2.00	\$ 2.21	2.50	\$ 2.94
3	25(1")	34mm			2.00	\$ 3.05	3.00	\$ 4.62
4	35(1 1/4")	42mm	1.50	\$ 2.84	2.00	\$ 3.89	3.10	\$ 5.99
5	40(1 1/2")	49mm	1.50	\$ 3.26	2.30	\$ 5.15	3.50	\$ 7.79
6	55(2")	60mm	1.80	\$ 4.83	2.90	\$ 8.09	4.30	\$ 12.08
7	65( 2 1/2")	75mm	2.20	\$ 7.88	3.50	\$ 12.60	5.40	\$ 19.95
8	80(3")	90mm	2.50	\$ 10.50	4.10	\$ 17.85	6.40	\$ 31.50
9	100(4")	114mm	3.20	\$ 17.85	5.20	\$ 29.40	8.10	\$ 52.50
10	120(5")	125mm	3.90	\$ 26.25	6.40	\$ 44.10	9.90	\$ 84.00
11	150(6")	165mm	4.60	\$ 36.75	7.50	\$ 63.00	11.70	\$ 115.50
12	200(8")	200mm	5.40	\$ 57.75	8.80	\$ 105.00	13.70	\$ 178.50
13	250(10")	250mm	6.60	\$ 89.25	10.90	\$ 157.50	16.90	\$ 262.50
14	300(12")	300mm	7.80	\$ 126.00	12.90	\$ 262.50	20.10	\$ 367.50
15	350(14")	350mm	9.10	\$ -	15.00	\$ 315.00	23.40	\$ -
16	400(16")	400mm	10.30	\$ 210.00	17.00	\$ 420.00	26.50	\$ 630.00

We have a wide range of Polyvinyl Chloride (PVC) and unplasticized Polyvinyl Chloride (uPVC) pipe for various applications. Jointing is by using solvent cements which is easy and leak-proof.

**Application:** Portable Water, Soil, Waste Water, Vent Pipe, Drainage, Underground Pipe for Sewerage, Telecom Pipe

**Advantages:** Lightweight, High Strength, Low reactivity, fused using solvent cements creating permanent joint which is leak-proof, Non toxic, Low co-efficient of expansions, Withstand working temperature of 50C to 750C, Low Maintenance, Does not corrode

**Approval:** Our pipe is certified by SIRIM to MS762 (BS3506), MS628 (BS3505) for pressure pipe and MS978 (BS5255), MS1063 (BS4514) and MS979 (BS4660) for Soil, Waste and Vent pipes.

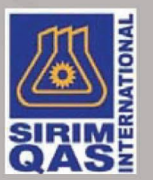







ផ្ទះលេខ១៥ ផ្លូវ៣៧១ សង្កាត់ ទឹកថ្លា ខ័ណ្ឌ សែនសុខ រាជធានីភ្នំពេញ ប្រទេសកម្ពុជា.

Tel: 016 878852/066 788898. Email: hordarastar@yahoo.com



# S4 Co., Ltd

 សុង (ក្រាស់)		 កែង 45 (ក្រាស់)		 សុងបង្រួម (ក្រាស់)		 តេបង្រួម (ក្រាស់)	
ទំហំតំណាង	តំលៃ(ដុល្លារ)	ទំហំតំណាង	តំលៃ(ដុល្លារ)	ទំហំតំណាង	តំលៃ(ដុល្លារ)	ទំហំតំណាង	តំលៃ(ដុល្លារ)
C18mm	\$ 0.123	B18mm	\$ 0.184	RC20 x 18 (3/4"x 1/2"	\$ 0.159	RT20 x 18 (3/4"x 1/2"	\$ 0.282
C20mm	\$ 0.158	B20mm	\$ 0.291	RC25 x 18 (1" x 1/2"	\$ 1.266	RT25 x 18 (1" x 1/2"	\$ 0.662
C25mm	\$ 0.261	B25mm	\$ 0.445	RC25 x 20 (1" x 3/4"	\$ 0.265	RT25 x 20 (1" x 3/4"	\$ 0.663
C35mm	\$ 0.389	B35mm	\$ 0.600	RC35 x 18 (1 1/4" x 1/2"	\$ 0.423	RT35 x 18 (1 1/4" x 1/2"	\$ 1.245
C40mm	\$ 0.499	B40mm	\$ 0.900	RC35 x 20 (1 1/4" x 3/4"	\$ 0.423	RT35 x 20 (1 1/4" x 3/4"	\$ 1.245
C55mm	\$ 0.782	B55mm	\$ 1.709	RC35 x 25 (1 1/4" x 1"	\$ 0.496	RT35 x 25 (1 1/4" x 1"	\$ 1.450
C65mm	\$ 1.286	B65mm	\$ 3.034	RC40 x 18 (1 1/2" x 1/2"	\$ 0.497	RT40 x 18 (1 1/2" x 1/2"	\$ 1.450
C80mm	\$ 2.136	B80mm	\$ 4.786	RC40 x 20 (1 1/2" x 3/4"	\$ 0.497	RT40 x 20 (1 1/2" x 3/4"	\$ 1.450
C100mm	\$ 3.845	B100mm	\$ 9.912	RC40 x 25 (1 1/2" x 1"	\$ 0.497	RT40 x 25 (1 1/2" x 1"	\$ 1.450
C150mm	\$ 13.885	B150mm	\$ 20.000	RC40 x 35 (1 1/2" x 1 1/4"	\$ 0.497	RT40 x 35 (1 1/2" x 1 1/4"	\$ 1.450
 កែង 90 (ក្រាស់)		 តេ (ក្រាស់)		RC55 x 18 (2" x 1/2"	\$ 0.798	RT55 x 18 (2" x 1/2"	\$ 2.000
				RC55 x 20 (2" x 3/4"	\$ 0.798	RT55 x 20 (2" x 3/4"	\$ 2.000
				RC55 x 25 (2" x 1"	\$ 0.798	RT55 x 25 (2" x 1"	\$ 2.000
				RC55 x 35 (2" x 1 1/4"	\$ 0.798	RT55 x 35 (2" x 1 1/4"	\$ 2.300
				RC55 x 40 (2" x 1 1/2"	\$ 0.798	RT55 x 40 (2" x 1 1/2"	\$ 2.300
ទំហំតំណាង    តំលៃ(ដុល្លារ)		ទំហំតំណាង    តំលៃ(ដុល្លារ)		RC65 x 18 (2 1/2" x 1/2"	\$ 1.453	RT65 x 18 (2 1/2" x 1/2"	\$ 3.800
				RC65 x 20 (2 1/2" x 3/4"	\$ 1.453	RT65 x 20 (2 1/2" x 3/4"	\$ 3.800
				RC65 x 25 (2 1/2" x 1"	\$ 1.453	RT65 x 25 (2 1/2" x 1"	\$ 3.800
				RC65 x 35 (2 1/2" x 1 1/4"	\$ 1.453	RT65 x 35 (2 1/2" x 1 1/4"	\$ 3.800
				RC65 x 40 (2 1/2" x 1 1/2"	\$ 1.453	RT65 x 40 (2 1/2" x 1 1/2"	\$ 3.800
E18mm	\$ 0.149	T18mm	\$ 0.205	RC65 x 55 (2 1/2" x 2"	\$ 1.453	RT65 x 55 (2 1/2" x 2"	\$ 3.800
E20mm	\$ 0.200	T20mm	\$ 0.282	RC80 x 18 (3" x 1/2"	\$ 2.880	RT80 x 18 (3" x 1/2"	\$ 4.500
E25mm	\$ 0.363	T25mm	\$ 0.534	RC80 x 20 (3" x 3/4"	\$ 2.880	RT80 x 20 (3" x 3/4"	\$ 4.500
E35mm	\$ 0.624	T35mm	\$ 0.760	RC80 x 25 (3" x 1"	\$ 2.880	RT80 x 25 (3" x 1"	\$ 4.500
E40mm	\$ 0.782	T40mm	\$ 1.098	RC80 x 35 (3" x 1 1/4"	\$ 2.880	RT80 x 35 (3" x 1 1/4"	\$ 6.770
E55mm	\$ 1.184	T55mm	\$ 1.800	RC80 x 40 (3" x 1 1/2"	\$ 2.880	RT80 x 40 (3" x 1 1/2"	\$ 6.770
E65mm	\$ 2.499	T65mm	\$ 3.80	RC80 x 65 (3" x 2 1/2"	\$ 2.880	RT80 x 65 (3" x 2 1/2"	\$ 6.770
E80mm	\$ 3.504	T80mm	\$ 6.80	RC100 x 18 (4" x 1/2"	\$ 3.900	RT100 x 18 (4" x 1/2"	\$ 14.800
E100mm	\$ 6.835	T100mm	\$ 14.60	RC100 x 18 (4" x 1/2"	\$ 3.900	RT100 x 18 (4" x 1/2"	\$ 14.800
E125mm	\$ 21.79	T125mm	\$ 98.36	RC100 x 20 (4" x 3/4"	\$ 3.900	RT100 x 20 (4" x 3/4"	\$ 14.800
E150mm	\$ 59.813	T150mm	\$ 98.36	RC100 x 25 (4" x 1"	\$ 3.900	RT100 x 25 (4" x 1"	\$ 14.800
E200mm	\$ 363.32	T200mm	\$ 491.80	RC100 x 35 (4" x 1 1/4"	\$ 3.900	RT100 x 35 (4" x 1 1/4"	\$ 14.800
E250mm	\$ 485.34	T250mm	\$ 717.42	RC100 x 40 (4" x 1 1/2"	\$ 3.900	RT100 x 40 (4" x 1 1/2"	\$ 14.800
E300mm	\$ 945.82	T300mm	\$ 1,030.00	RC100 x 55 (4" x 2"	\$ 3.900	RT100 x 55 (4" x 2"	\$ 14.800
				RC100 x 65 (4" x 2 1/2"	\$ 3.900	RT100 x 65 (4" x 2 1/2"	\$ 14.800
				RC100 x 80 (4" x 3"	\$ 3.900	RT100 x 80 (4" x 3"	\$ 14.800
				RT150 x 80 (6" x 3"	\$ 55.800		
				RT150 x 100 (6" x 4"	\$ 65.000		
				RT200 x 100 (8" x 4"	\$ 370.000		

ផ្ទះលេខ១៥ ផ្លូវ៣៧១ សង្កាត់ ទឹកថ្លា ខ័ណ្ឌ សែនសុខ រាជធានីភ្នំពេញ ប្រទេសកម្ពុជា.

Tel: 016 878852/066 788898. Email: hordarastar@yahoo.com



# S4 Co., Ltd













							
គ្រប (ក្រាស់)		ស្នង ឆ្នើង		តេ ឆ្នើង		ប្រឹង (ក្រាស់)	
ទំហំតំណរ	តំលៃ(ដុល្លារ)	ទំហំតំណរ	តំលៃ(ដុល្លារ)	ទំហំតំណរ	តំលៃ(ដុល្លារ)	ទំហំតំណរ	តំលៃ(ដុល្លារ)
EC18mm	\$ 0.129	THC35mm	\$ 0.213	THT35mm	\$ 0.330	F55mm	\$ 13.250
EC20mm	\$ 0.189	THC40mm	\$ 0.230	THT40mm	\$ 0.543	F65mm	\$ 18.550
EC25mm	\$ 0.286	THC55mm	\$ 0.340	THT55mm	\$ 0.662	F80mm	\$ 24.000
EC35mm	\$ 0.426	THC65mm	\$ 0.620	THT65mm	\$ 1.120	F100mm	\$ 31.000
EC40mm	\$ 0.630	THC80mm	\$ 0.989	THT80mm	\$ 1.680	F150mm	\$ 72.000
EC55mm	\$ 0.950	THC100mm	\$ 1.398	THT100mm	\$ 3.980		
EC65mm	\$ 1.790	THC125mm	\$ 4.490	THT125mm	\$ 10.000		
EC80mm	\$ 2.500	THC150mm	\$ 7.480	THT150mm	\$ 18.750		
EC100mm	\$ 4.700			THT200mm	\$ 65.000		
							
កែង 45 ឆ្នើង		កែង 90 ឆ្នើង		តេបង្រួម ឆ្នើង		ស្នងបង្រួម ឆ្នើង	
ទំហំតំណរ	តំលៃ(ដុល្លារ)	ទំហំតំណរ	តំលៃ(ដុល្លារ)	ទំហំតំណរ	តំលៃ(ដុល្លារ)	ទំហំតំណរ	តំលៃ(ដុល្លារ)
THB35mm	\$ 0.220	THE35mm	\$ 0.239	THRT40mm x 35mm	\$ 0.291	THRC40mm x 35mm	\$ 0.811
THB40mm	\$ 0.280	THE40mm	\$ 0.286	THRT55mm x 35mm	\$ 0.478	THRC55mm x 35mm	\$ 0.914
THB55mm	\$ 0.422	THE55mm	\$ 0.496	THRT55mm x 40mm	\$ 0.498	THRC55mm x 40mm	\$ 1.115
THB65mm	\$ 0.795	THE65mm	\$ 0.811	THRT65mm x 40mm	\$ 0.700	THRC65mm x 40mm	\$ 1.611
THB80mm	\$ 1.210	THE80mm	\$ 1.492	THRT65mm x 55mm	\$ 0.987	THRC65mm x 55mm	\$ 1.910
THB100mm	\$ 3.100	THE100mm	\$ 3.040	THRT80mm x 40mm	\$ 1.077	THRC80mm x 40mm	\$ 1.115
THB125mm	\$ 5.560	THE125mm	\$ 6.400	THRT80mm x 55mm	\$ 1.154	THRC80mm x 55mm	\$ 1.611
THB150mm	\$ 9.900	THE150mm	\$ 12.700	THRT80mm x 65mm	\$ 1.726	THRC80mm x 65mm	\$ 1.910
THB200mm	\$ 25.500	THE200mm	\$ 28.500	THRT100mm x 40mm	\$ 1.726	THRC100mm x 40mm	\$ 2.564
THB250mm	\$ 93.000	THE250mm	\$ 94.800	THRT100mm x 55mm	\$ 1.854	THRC100mm x 55mm	\$ 4.487
THB300mm	\$ 275.000	THE300mm	\$ 225.000	THRT100mm x 65mm	\$ 2.064	THRC100mm x 65mm	\$ 4.914
				THRT100mm x 80mm	\$ 2.064	THRC100mm x 80mm	\$ 5.299
				THRT150mm x 100mm	\$ 7.904	THRC150mm x 100mm	\$ 20.507
							
យូត្រែប ឆ្នើង		អេស ត្រែប ឆ្នើង		កីត្រែប ឆ្នើង		ឆ្នុកបូម (ឆ្នើង)	
ទំហំតំណរ	តំលៃ(ដុល្លារ)	ទំហំតំណរ	តំលៃ(ដុល្លារ)	ទំហំតំណរ	តំលៃ(ដុល្លារ)	ទំហំតំណរ	តំលៃ(ដុល្លារ)
U55mm	\$ 9.000	S55mm	\$ 16.240	P55mm	\$ 9.500	MHC100mm	\$ 6.700

ផ្ទះលេខ១៥ ផ្លូវ៣៧១ សង្កាត់ ទឹកថ្លា ខណ្ឌ សែនសុខ រាជធានីភ្នំពេញ ប្រទេសកម្ពុជា.

Tel: 016\_878852/066\_788898. Email: hordarastar@yahoo.com.....



# S4 Co., Ltd

 សុងធ្មេញក្រៅ (ក្រាស់)		 សុងធ្មេញក្នុង (ក្រាស់)		 សុងធ្មេញក្រៅស្ពាន់ (ក្រាស់)		 សុងធ្មេញក្នុងស្ពាន់ (ក្រាស់)	
ទំហំតំណាង	តំលៃ(ដុល្លារ)	ទំហំតំណាង	តំលៃ(ដុល្លារ)	ទំហំតំណាង	តំលៃ(ដុល្លារ)	ទំហំតំណាង	តំលៃ(ដុល្លារ)
MC18mm x 1/2"	\$ 0.110	FC18mm x 1/2"	\$ 0.129	BMC18mm x 1/2"	\$ 1.500	BFC18mm x 1/2"	\$ 1.120
MC20mm x 3/4"	\$ 0.159	FC20mm x 3/4"	\$ 0.189	BMC20mm x 3/4"	-	BFC20mm x 3/4"	\$ 1.498
MC25mm x 1"	\$ 0.236	FC25mm x 1"	\$ 0.317	BMC25mm x 1"	-	BFC25mm x 1"	\$ 2.140
MC35mm x 1 1/4"	\$ 0.423	FC35mm x 1 1/4"	\$ 0.52	BMC40mm x 1 1/2"	-	BFC40mm x 1 1/2"	\$ 6.200
MC40mm x 1 1/2"	\$ 0.520	FC40mm x 1 1/2"	\$ 0.74	BMC55mm x 2"	-	BFC55mm x 2"	\$ 9.100
MC55mm x 2"	\$ 0.740	FC55mm x 2"	\$ 1.20				
MC65mm x 1 1/2"	\$ 1.500	FC65mm x 1 1/2"	\$ 1.79				
MC80mm x 3"	\$ 1.980	FC80mm x 3"	\$ 2.38				
MC100mm x 4"	\$ 4.000	FC100mm x 4"	\$ 4.28				
 កែងធ្មេញក្រៅ (ក្រាស់)		 កែងធ្មេញក្នុង(ក្រាស់)		 កែងធ្មេញក្រៅស្ពាន់ (ក្រាស់)		 កែងធ្មេញក្នុងស្ពាន់ (ក្រាស់)	
ទំហំតំណាង	តំលៃ(ដុល្លារ)	ទំហំតំណាង	តំលៃ(ដុល្លារ)	ទំហំតំណាង	តំលៃ(ដុល្លារ)	ទំហំតំណាង	តំលៃ(ដុល្លារ)
ME18mm x 1/2"	\$ 0.300	FE18mm x 1/2"	\$ 0.240	BME18mm x 1/2"	\$ 1.800	BFE18mm x 1/2"	\$ 1.400
ME20mm x 3/4"	\$ 0.350	FE20mm x 3/4"	\$ 0.360			BFE20mm x 3/4"	\$ 2.000
ME25mm x 1"	\$ 0.640	FE25mm x 1"	\$ 0.690			BFE25mm x 1"	\$ 3.100
 តេធ្មេញក្រៅ (ក្រាស់)		 តេធ្មេញក្នុង (ក្រាស់)		 តេធ្មេញក្រៅស្ពាន់ (ក្រាស់)		 តេធ្មេញក្នុងស្ពាន់ (ក្រាស់)	
ទំហំតំណាង	តំលៃ(ដុល្លារ)	ទំហំតំណាង	តំលៃ(ដុល្លារ)	ទំហំតំណាង	តំលៃ(ដុល្លារ)	ទំហំតំណាង	តំលៃ(ដុល្លារ)
MT18mm x 1/2"	\$ 0.500	FT18mm x 1/2"	\$ 0.420	BMT18mm x 1/2"		BFT18mm x 1/2"	
MT20mm x 3/4"	\$ 0.879	FT20mm x 3/4"	\$ 0.560	BMT20mm x 3/4"		BFT20mm x 3/4"	
MT25mm x 1"	\$ 1.000	FT25mm x 1"	\$ 0.870	BMT25mm x 1"		BFT25mm x 1"	
 គម្រប់ធ្មេញក្រៅ (ក្រាស់)		 គម្រប់ធ្មេញក្នុង (ក្រាស់)		 គម្រប់ធ្មេញក្រៅស្ពាន់ (ក្រាស់)		 គម្រប់ធ្មេញក្នុងស្ពាន់ (ក្រាស់)	
ទំហំតំណាង	តំលៃ(ដុល្លារ)	ទំហំតំណាង	តំលៃ(ដុល្លារ)	ទំហំតំណាង	តំលៃ(ដុល្លារ)	ទំហំតំណាង	តំលៃ(ដុល្លារ)
MEC18mm x 1/2"	\$ 0.070	FEC18mm x 1/2"	\$ 0.150				
MEC20mm x 3/4"	\$ 0.090	FEC55mm x 2"	\$ 1.200				
MEC25mm x 1"	\$ 0.150						

CATALOGUE

ផ្លូវលំ ភូមិ ឫស្សីសង្កាត់ ស្ទឹងមានជ័យ ខ័ណ្ឌមានជ័យ រាជធានីភ្នំពេញ ប្រទេសកម្ពុជា.

Tel: 016 878852/066 788898. Email: hordarastar@yahoo.com



# S4 Co., Ltd

សុងធ្មេញក្រៅសងខាង (ក្រាស់)		សុងធ្មេញក្នុង ក្រៅ (ក្រាស់)		តេអ៊ីការិច (ស្មើង)		អ៊ីការិច (ស្មើង)	
ទំហំតំណរ	តំលៃ(ដុល្លារ)	ទំហំតំណរ	តំលៃ(ដុល្លារ)	ទំហំតំណរ	តំលៃ(ដុល្លារ)	ទំហំតំណរ	តំលៃ(ដុល្លារ)
MA18mm x 1/2"	\$ 0.149	FMA18mm x 1/2"	\$ 0.138	TY55mm	\$ 1.445	Y55mm	\$ 1.470
MA20mm x 3/4"	\$ 0.171	FMA20mm x 3/4"	\$ 0.240	TY65mm	\$ 3.080	Y65mm	\$ 2.714
MA25mm x 1"	\$ 0.299	FMA25mm x 1"	\$ 0.240	TY80mm	\$ 3.973	Y80mm	\$ 3.571
				TY100mm	\$ 7.477	Y100mm	\$ 6.878
				TY125mm	\$ -	Y125mm	\$ -
				TY150mm	\$ 25.634	Y150mm	\$ 31.616
តែងបង្រួម (ក្រាស់)		អ៊ីការិចមុខបួន (ស្មើង)		តេអ៊ីការិចបង្រួម (ស្មើង)		អ៊ីការិចបង្រួម (ស្មើង)	
ទំហំតំណរ	តំលៃ(ដុល្លារ)	ទំហំតំណរ	តំលៃ(ដុល្លារ)	ទំហំតំណរ	តំលៃ(ដុល្លារ)	ទំហំតំណរ	តំលៃ(ដុល្លារ)
RE20 x 18 (3/4"x 1/2")	\$ 0.213	4Y80mm	\$ -				
RE25 x 18 (1" x 1/2")	\$ 0.406	4Y100mm	\$ 24.566	តេអ៊ីការិចបង្រួម (ស្មើង)		អ៊ីការិចបង្រួម (ស្មើង)	
RE25 x 20 (1" x 3/4")	\$ 0.470			ទំហំតំណរ	តំលៃ(ដុល្លារ)	ទំហំតំណរ	តំលៃ(ដុល្លារ)
				RTY65mm x 40mm	\$ 3.080	RY65mm x 40mm	\$ 2.990
				RTY65mm x 55mm	\$ 3.418	RY65mm x 55mm	\$ 3.205
				RTY80mm x 40mm	\$ 4.059	RY80mm x 40mm	\$ 4.059
				RTY80mm x 55mm	\$ 5.126	RY80mm x 55mm	\$ 4.486
ក្រចាបជ័រ (ក្រាស់)		វ៉ានជ័រ (ក្រាស់)		RTY80mm x 65mm	\$ 6.408	RY80mm x 65mm	\$ 4.914
ទំហំតំណរ	តំលៃ(ដុល្លារ)	ទំហំតំណរ	តំលៃ(ដុល្លារ)	RTY100mm x 40mm	\$ 6.440	RY100mm x 40mm	\$ 5.981
CL18mm	\$ 0.056	V18mm	\$ 1.462	RTY100mm x 55mm	\$ 6.440	RY100mm x 55mm	\$ 5.981
CL20mm	\$ 0.059	V20mm	\$ 2.011	RTY100mm x 65mm	\$ 7.500	RY100mm x 65mm	\$ 6.835
CL25mm	\$ 0.098	V25mm	\$ 2.926	RTY100mm x 80mm	\$ 7.700	RY100mm x 80mm	\$ 7.050
CL35mm	\$ 0.374	V35mm	\$ 4.914	RTY125mm x 100mm	\$ -	RY125mm x 100mm	\$ -
CL40mm	\$ 0.598	V40mm	\$ 6.858	RTY150mm x 80mm	\$ 25.640	RY150mm x 80mm	\$ 18.371
CL55mm	\$ 0.683	V55mm	\$ 8.686	RTY150mm x 100mm	\$ 26.020	RY150mm x 100mm	\$ 23.370
CL65mm	\$ 0.939	V65mm	\$ 24.994				
CL80mm	\$ 1.300	V80mm	\$ 28.626				
CL100mm	\$ 1.538	V100mm	\$ 66.008				

CATALOGUE OF PROD

ផ្ទះលេខ១៥ ផ្លូវ៣៧១ សង្កាត់ ទឹកថ្លា ខ័ណ្ឌ សែនសុខ រាជធានីភ្នំពេញ ប្រទេសកម្ពុជា.

Tel: 016 878852/066 788898. Email: hordarastar@yahoo.com



# S4 Co., Ltd

## 1) ROUND TANK

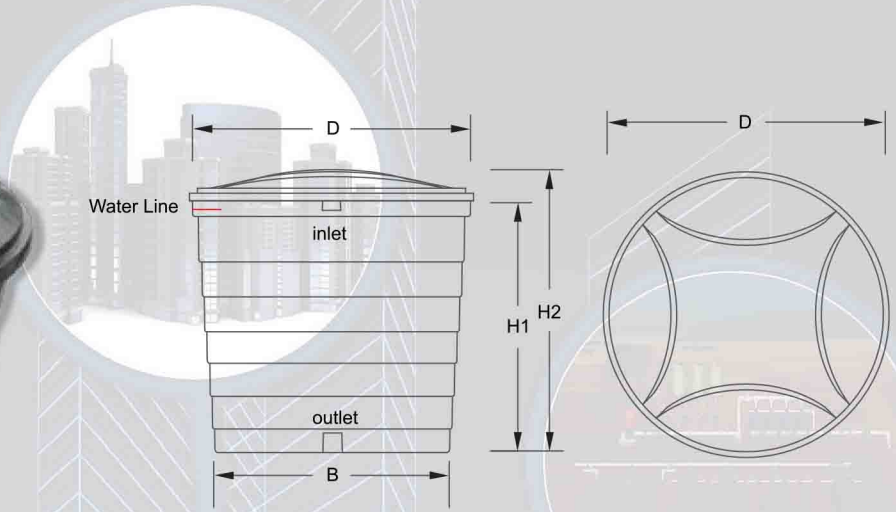

PE COLD WATER STORAGE TANK (ROUND) DIMENSION

ROUND Model	NOMINAL CAPACITY		MAXIMUM CAPACITY		DIMENSION		
	Litres	Gallons	Litres	Gallons	Diameter (D)	Eave Height (H1)	Overall Height (H2)
N50	230	50	365	80	45	20	24
N70	365	80	455	100	48	21	25
N100	455	100	685	150	52	25	31
N150	685	150	910	200	62	26	33
N200	910	200	1135	250	61	33	40
N250	1135	250	1365	300	62	38	46
N300	1365	300	1820	400	63	52	59
N400	1820	400	2270	500	65	61	68
N500	2270	500	2730	600	71	59	66

\* All unit measurement are base on (inch)

PE COLD WATER STORAGE TANK (SPECIAL SIZE TANK ROUND) DIMENSION

ROUND Model	NOMINAL CAPACITY		MAXIMUM CAPACITY		DIMENSION		
	Litres	Gallons	Litres	Gallons	Diameter (D)	Base Height (B)	Overall Height (H2)
N40-SR1	180	40	270	60	34	26	28
N100-SR1	455	100	685	150	51	39	32
N150-SR1	685	150	910	200	51	39	41
N150-SR2	685	150	910	200	48	38	40
N150-SR3	685	150	910	200	50	37	45
N150-SR4	685	150	910	200	47	37	48
N200-SR1	910	200	1135	250	51	39	47
N200-SR2	910	200	1135	250	48	38	46
N200-SR3	910	200	1135	250	50	40	52
N250-SR1	1135	250	1365	300	48	38	53
N250-SR2	1135	250	1365	300	61	51	40
N250-SR3	1135	250	1365	300	60	50	35
N250-SR4	1135	250	1365	300	53	40	53
N250-SR5	1135	250	1365	300	48	40	58
N300-SR1	1365	300	1820	400	61	46	54

\* All unit measurement are base on (inch)

ផ្ទះលេខ១៥ ផ្លូវ៣៧១ សង្កាត់ ទឹកថ្លា ខ័ណ្ឌ សែនសុខ រាជធានីភ្នំពេញ ប្រទេសកម្ពុជា.

Tel: 016 878852/066 788898. Email: hordarastar@yahoo.com



# S4 Co., Ltd



## POLYETHYLENE INDIVIDUAL SEWAGE TREATMENT PLANT

Polyethylene Individual Sewage Treatment Plants are primarily manufactured to provide solution for domestic sewage by enhancing the treatment of wastewater to an acceptable level before disposing it into the open drain. This system is normally used for individual residential or commercial units when there is no alternative connection to the main sewage line or is located in remote area.

Polyethylene Individual Sewage Treatment Plants are durable, leak proof and long service product lifespan as it is manufactured in one piece seamless component using state of the art rotational moulding technology couple with the used of high quality polyethylene grade material. It is lightweight and easy to install as all

Polyethylene Individual Sewage Treatment Plants are supplied as a complete prefabricated unit with all necessary component preassemble for fast and easy installation. Each individual unit works on the principal of gravity flow through primary settlement and up flow filtration thus do not require any mechanical moving parts.

The introductions of the innovative Cosmo-Ball as the filter media for all of Polyethylene Individual Sewage Treatment Plants help enhance the treatment of wastewater by process of anaerobic digestion. Each individual Cosmo-Ball provides an optimum space for bacteria to breed which in turn will help maximize treatment of wastewater and keep tank clog free.



### POLYETHYLENE INDIVIDUAL SEWAGE TREATMENT PLANT FEATURES

- Product application : Domestic Sewage Treatment
- Available capacity : 5-8PE, 9-15PE & 13 - 30PE
- Standard colour : Black or Green (other colour on request)
- Finest polyethylene material
- One piece moulded and state of the art rotational moulding manufacturing technology
- Lightweight and easy to handle and install as all unit are supplied as a complete prefabricated
- The innovative Cosmo-Ball act as the filter media system that enhance the process of treatment of wastewater which contribute to longer product lifespan
- No mechanical parts as all system work principally on gravity flow mechanism
- Approve by SPAN, JPP & IWK

### POLYETHYLENE INDIVIDUAL SEWAGE TREATMENT PLANT DIMENSION

MODEL	CAPACITY		DIMENSION		
	PE Served	Volumn (litres)	Diameter (D)	Height (H)	Length (L)
RST 2	5-8	2000	1500	1760	N/A
RST 3	9-15	3000	1480	1650	2290
RST 5	13-30	5000	1840	1860	2885

*\* All unit measurement are base on (mm)*

ផ្ទះលេខ១៥ ផ្លូវ៣៧១ សង្កាត់ ទឹកថ្លា ខ័ណ្ឌ សែនសុខ រាជធានីភ្នំពេញ ប្រទេសកម្ពុជា.

Tel: 016 878852/066 788898. Email: hordarastar@yahoo.com





# S4 Co., Ltd

## POLYETHYLENE SEPTIC TANK PROFILE

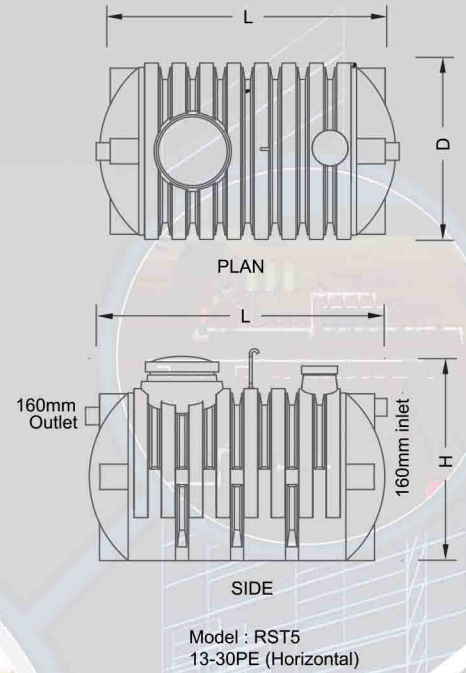
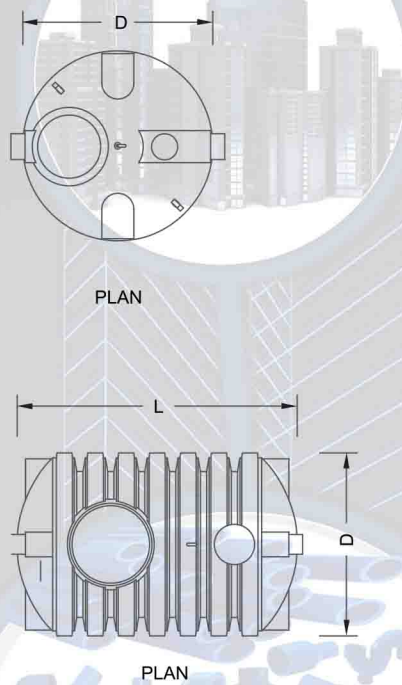
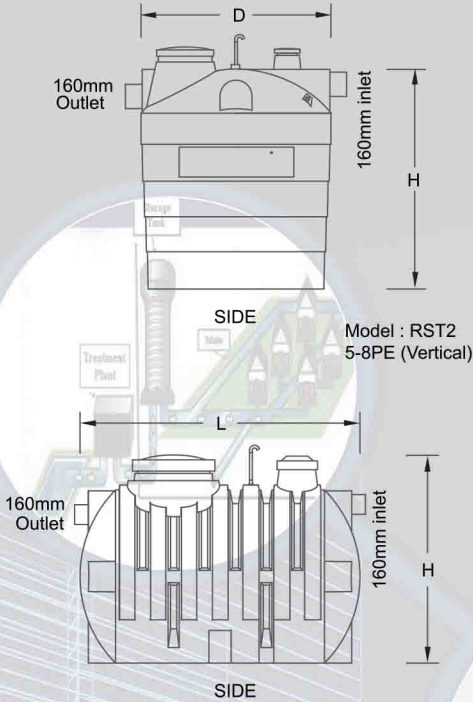

### TREATMENT PROCESS OF DOMESTIC WASTE WATER

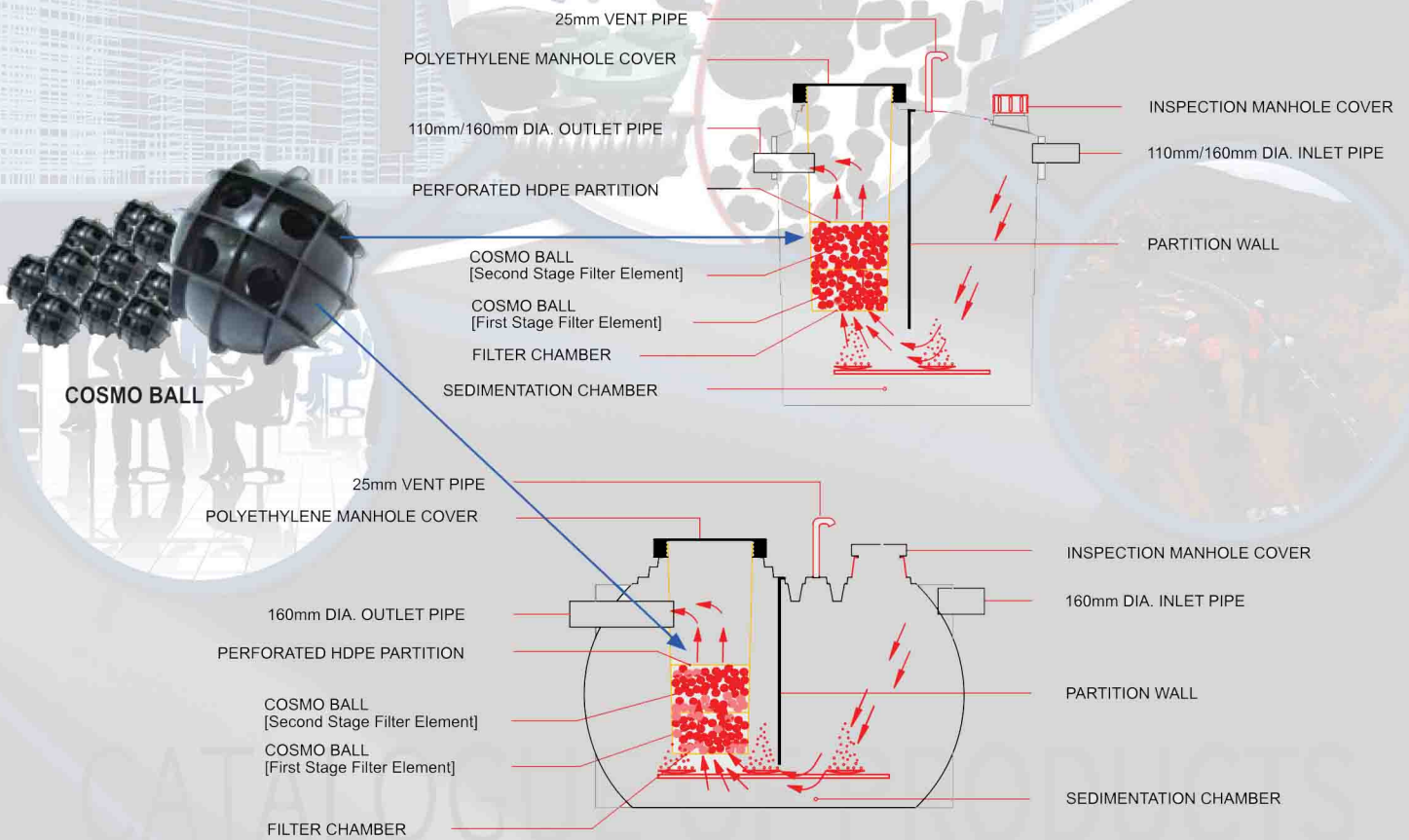

ផ្ទះលេខ១៥ ផ្លូវ៣៧១ សង្កាត់ ទឹកថ្លា ខ័ណ្ឌ សែនសុខ រាជធានីភ្នំពេញ ប្រទេសកម្ពុជា.

Tel: 016 878852/066 788898. Email: hordarastar@yahoo.com



# S4 Co., Ltd

CONTACT NO : 066 788 898 / 016 87 88 52

WHATSAPP / LINE / WECHAT NO : 066 788 898

EMAIL : [hordarastar@yahoo.com](mailto:hordarastar@yahoo.com)

## UPVC RAINGUTTER SYSTEM & ACCESSORIES PRICE LIST

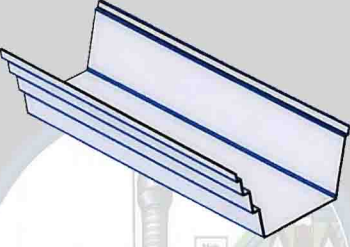
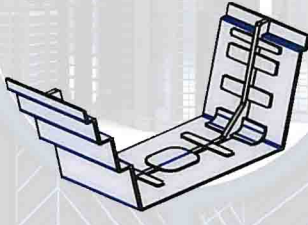
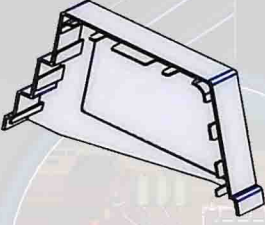
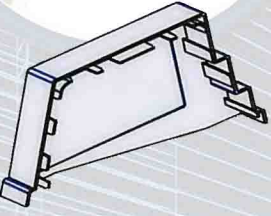
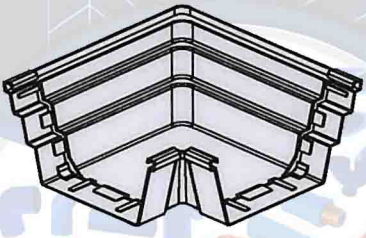
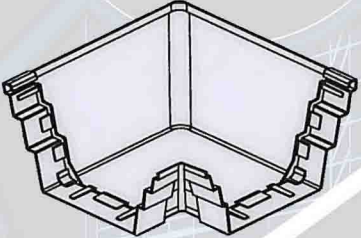
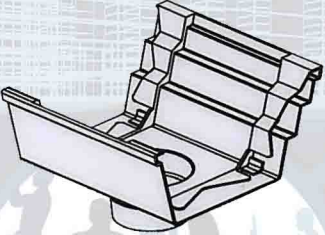
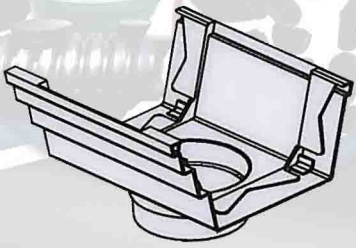
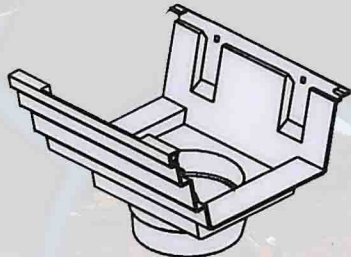
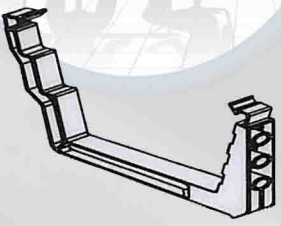
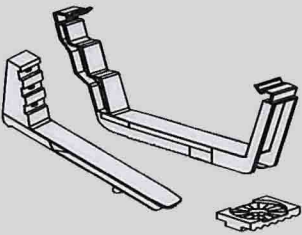
		
<b>RAINGUTTER PROFILE 5.8M</b>	<b>SOCKET JOINER</b>	<b>END CAP RIGHT</b>
RG2155.8(W) / RG2155.8(G)	RGSJ(W) / RGSJ(G)	RGEPR(W) / RGEPR(G)
USD 30.00	USD 1.60	USD 0.95
		
<b>END CAP LEFT</b>	<b>EXTERNAL CORNER</b>	<b>INTERNAL CORNER</b>
RGEPL(W) / RGEPL(G)	RGEC(W) / RGEC(G)	RGIC(W) / RGIC(G)
USD 0.95	USD 6.25	USD 6.25
		
<b>3" SPOUTHEAD</b>	<b>4" SPOUTHEAD</b>	<b>COMPRESS OUTLET</b>
RG3S(W) / RG3S(G)	RG4S(W) / RG4S(G)	RGCO(W) / RGCO(G)
USD 3.75	USD 4.70	USD 6.25
		
<b>90° HOLDER</b>	<b>ADJUSTABLE HOLDER</b>	
RG90H(W) / RG90H(G)	RGAH(W) / RGAH(G)	
USD 1.05	USD 1.60	

ផ្ទះលេខ១៥ ផ្លូវ៣៧១ សង្កាត់ ទឹកថ្លា ខ័ណ្ឌ សែនសុខ រាជធានីភ្នំពេញ ប្រទេសកម្ពុជា.

Tel: 016 878852/066 788898. Email: [hordarastar@yahoo.com](mailto:hordarastar@yahoo.com)